

TECHNICAL DATA



PRO	CRI ≥ 80	
IP65		120 L°
100-277V 50/60Hz		50000h L70

TYPE

BRAWNY LED is the reflector that achieves the most advanced result in industrial, sporting and large area lighting. Human centric Lighting (Lighting applications that focus on human wellbeing) Aesthetically pleasing and energy-saving light that lasts in time.

CHARACTERISTICS

- Nomial efficacy: 163.52 Lm/W
- Maximum LED: 1000mA
- Lifetime L90B10: >50,000 hours
- Luminous flux and efficacy aht 4000°K
- Luminous flux tolerance <+/-3%
- Values may be subject to change du LED binning
- Driver cable length: 30cm
- High efficiency Ra>80 LED

MATERIAL

- Die-cast aluminium, Transparent 4mm tempred-Glass
- Aluminum frame
- Steel Galvanized and painted bracket

Model:	Brawny
Format:	Round
Location:	Interior
Wattage:	200W
Materials:	Alu+Glass
Led Color:	3000K - 6500K - 7000K
Product Dimension:	D310mm
IP Code:	65
Fixation:	Suspended
CRI :	80
Lumen Output:	32,425LM
Frequency:	50/60 Hz
Beam Angle:	120°
Net weight:	2.4kgs

- Silver reflector: 0.37kgs
- Prisma reflector: 0.54kgs
- Black reflector: 0.37kgs

DIMENSION DRAW

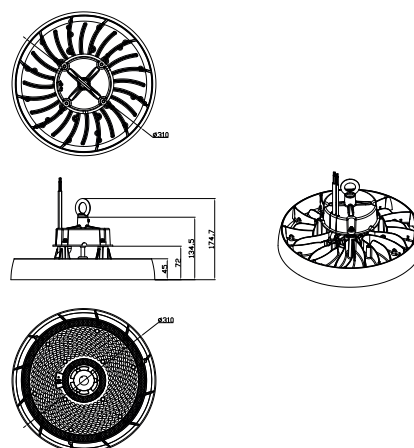

INDOOR